MQ-E3-0₃
Electrochemical Sensor

Manual

(Model: MQ-E3-0₃)

Version V1.2

Valid from May 1st,2014

Taiyuan Tengxing sensor technology Co., Ltd

MQ-E3-O₃ gas sensor

MQ-E3-O₃ electrochemical sensor detect gas concentration by measuring current based on the electrochemical principle, which utilizes the electrochemical oxidation process of target gas on the working electrode inside the electrolytic cell, the current produced in electrochemical reaction of the target gas are in direct proportion with its concentration while following Faraday law, then concentration of the gas could be get by measuring value of current.

1.Features

- * Low consumption
- * High precision
- * High sensitivity
- * Wide linear range
- * Good anti-interference ability
- * Excellent repeatability and stability

2 Application

Widely used in industrial and environmental protection fields

3. Technical Parameter

Detection gas	O ₃
Measurement Range	0~20ppm
Max detecting concentration	100ppm
Sensitivity	$(0.60 \pm 0.15) \mu\text{A/ppm}$
Resolution ratio	0.2ppm
Response time (T ₉₀)	≤120S
Bias voltage	0mV
Load resistance	10 Ω (recommended)
Repeatability	<5% output value
Stability (/ month)	<2%
Output Linearity	linear
Zero drift (-20°C~40°C)	0.2ppm
Storage temperature	-20°C~50°C
Storage Humidity	15%~90% RH
Pressure range	Standard atmosphere pressure ±10%
Anticipated using life	2 years (In air)

4. External dimension

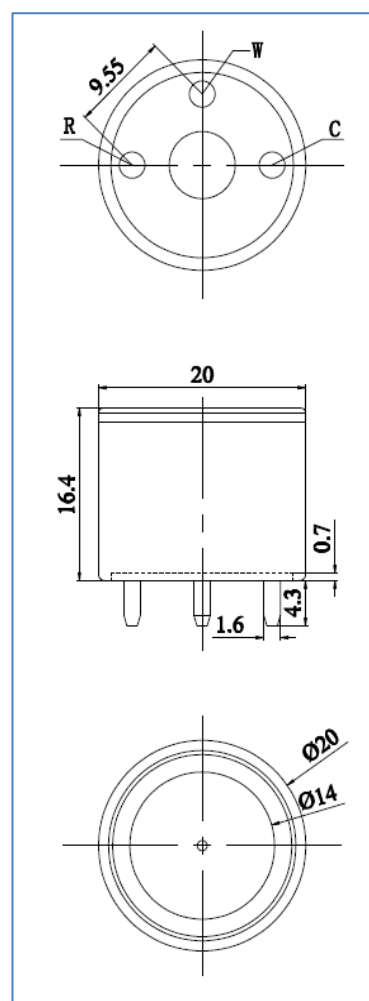

5.Characterization

Features of Sensitivity, response and resume

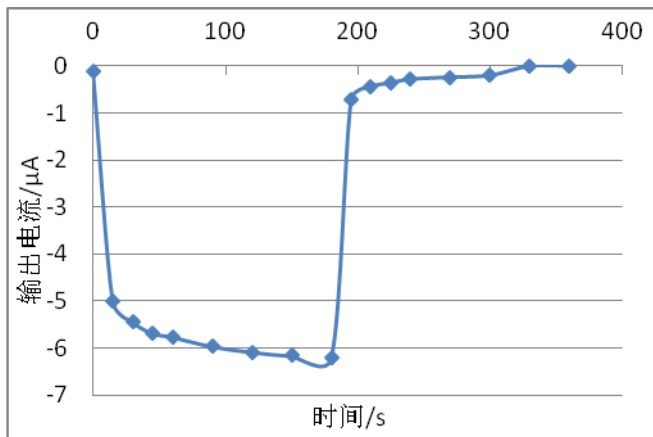

Linearity features

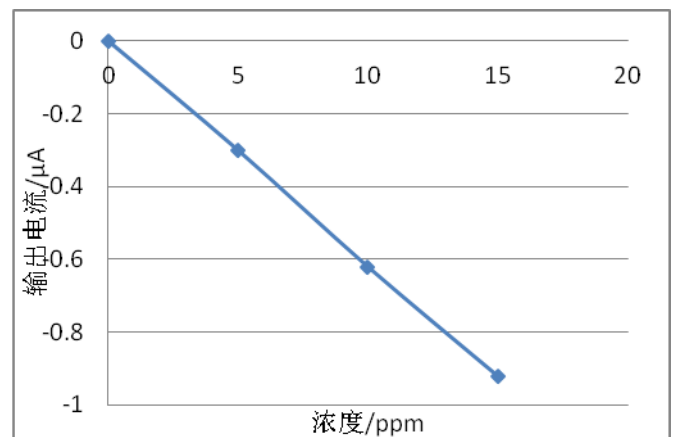

Zero point change upon Variable Temperature

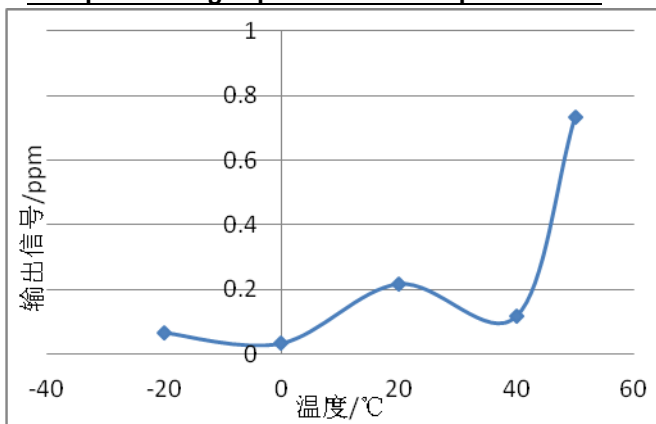

Output upon variable temperature

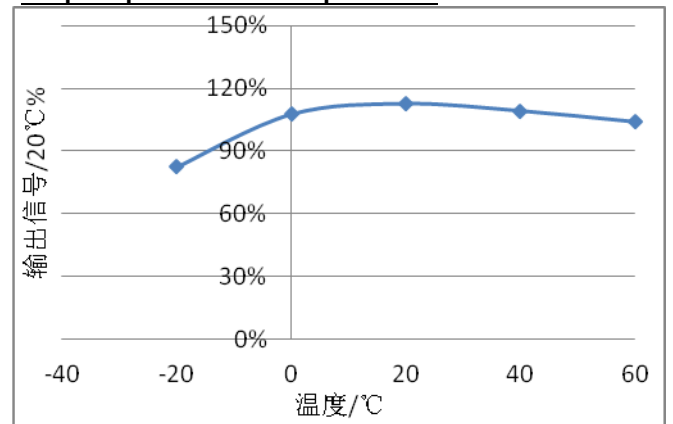

6.Basic circuit

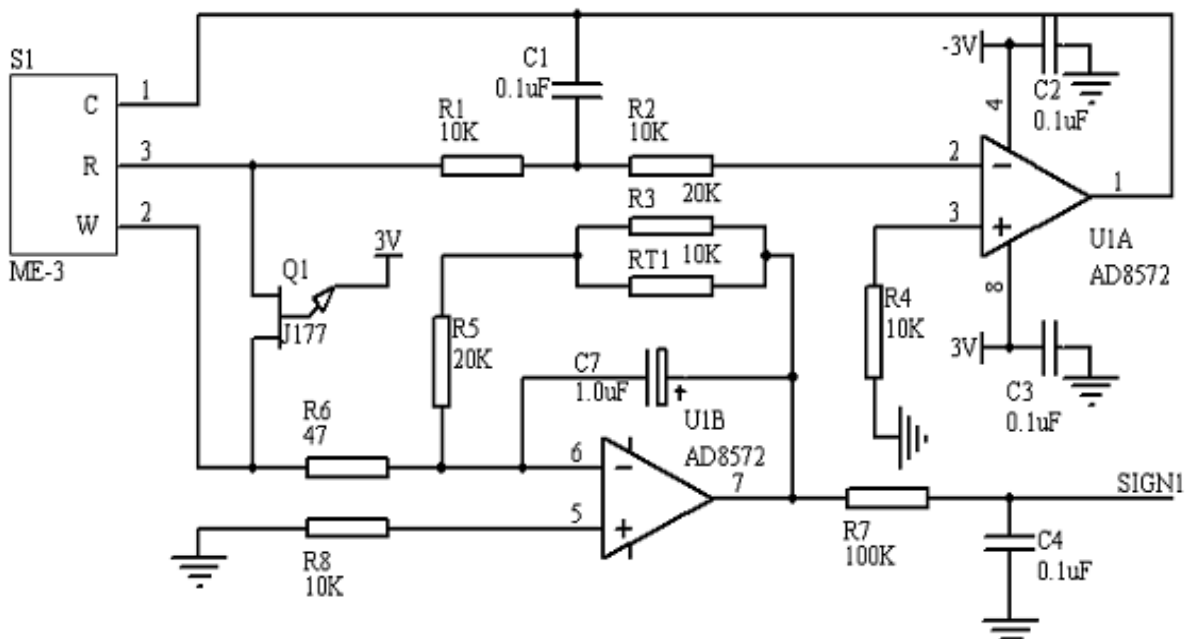

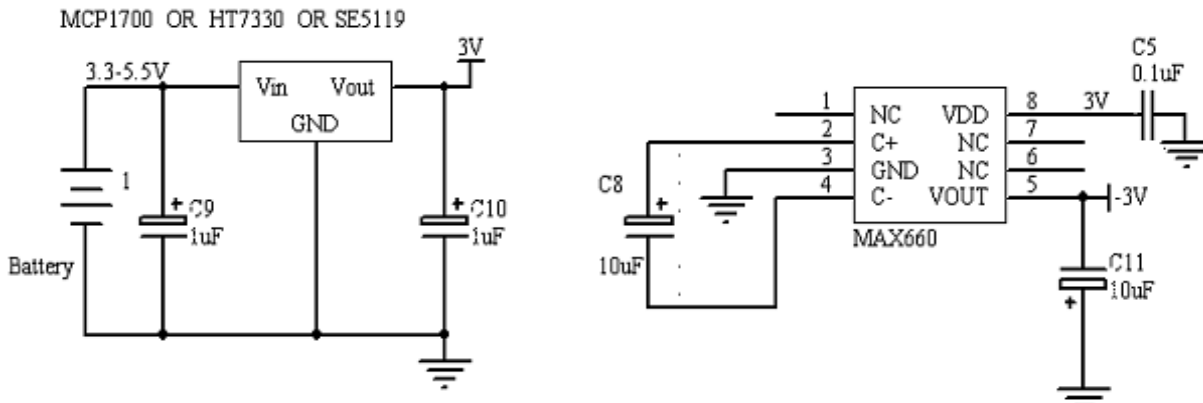

7. Anti-Interference:

MQ-E3-O₃ sensor also responds to other gases besides target gas. Below are the response characteristics of interferential gases

Gas	Concentration	MQ-E3-O ₃
CL ₂	3ppm	1ppm
H ₂ S	15ppm	<-1ppm
CO	300ppm	0ppm
SO ₂	5ppm	0ppm
HCN	10ppm	0ppm
HCL	5ppm	0ppm
NO	35ppm	0ppm
NO ₂	5ppm	2ppm
H ₂	500ppm	0ppm
C ₂ H ₄	100ppm	0ppm

8. Application Notes:

- Sensor shall Avoid organic solvent, coatings, medicine, oil and high concentration gases;
- All ME Sensors shall not be encapsulated completely by resin materials, and shall not immerse in oxygen-free environment, otherwise, it will damage the function of sensor;
- All ME sensors shall not be applied in corrosive gas environment, or the sensor will be damaged;
- Please test the sensitivity of gas sensors in clean atmosphere;
- Sensors Shall be avoided to face the gas, which flow directly from front side;
- To avoid to bend and break of pins;
- Blowhole of the sensor should not be blocked and polluted, which will cause the sensitivity

decrease;

- Excessive impact or vibration should be avoided;
- Do not use the sensor when the shell is damaged;
- It takes some time for the sensor to return to normal state After applied in high concentration gas;
- Do not take apart the sensor, otherwise electrolyte leakage can cause sensor damage;
- Working electrode and reference electrode of the sensor shall be in short circuit when stored.;
- To preheat over 48hs before using and soldering forbidden;

Note: To keep continual product development, we reserve right to change design features without prior notice !

