



# Hydrogen Gas Sensor

(Model: MQ-E4-H<sub>2</sub>)

# Manual

Version: 1.3

Valid from: 2022-06-10

Taiyuan Tengxing sensor technology Co., Ltd

# Statement

1. The copyright of instructions belong to Taiyuan Tengxing sensor technology Co., Ltd(hereinafter referred to as the Company), nobody is allowed to copy, translate, spread or store without written approval.
2. Thanks for using our product. In order to use the products more smoothly, reduce faults result from inappropriate using, please read the instructions carefully before using and follow the rules suggested strictly. Anyone who don ' t follow the instructions, disassemble or change the internal components without permission will afford the loss.
3. The color, style and size of the product is subject to the object you received.
4. The company follows the idea of scientific and technological progress, make efforts to product-improving and technology-innovating. So we have the right to improve product without prior notice.
5. Please make sure it ' s valid before using the instructions. Any good suggestions from you is welcomed.
6. The instructions should be well kept.

Taiyuan Tengxing sensor technology Co., Ltd

## MQ-E4-H<sub>2</sub> Hydrogen Gas Sensor

### Profile

MQ-E<sub>4</sub>H<sub>2</sub> hydrogen gas sensor is constant potential electrolysis type. Oxidation-reduction reaction with hydrogen and oxygen take place respectively on the working electrode and on the counter electrode. The process releases electric charge and generates current. The current is in direct proportion to the concentration of hydrogen. So the concentration of the target gas could be got by measuring the value of current.

### Features

Low power consumption, high precision, high sensitivity, wide linear range, good anti-interference ability, excellent repeatability and stability.

### Main applications

It is used for hydrogen detection in industrial occasion and environmental protection field.

### Technical Parameters      Stable1.

Detection Gas	hydrogen (H <sub>2</sub> )
Detection Range	0~1000ppm
Max range	2000ppm
Sensitivity	(10.8±5.2) nA/ppm
Resolution	1ppm
Response Time(T <sub>90</sub> )	≤30S
Bias Voltage	0mV
Load Resistance	10Ω(recommended)
Repeatability	<2% Output value
Stability(/month)	<2%
Output Linearity	Linear
Zero drift(-20℃~40℃)	≤10ppm
Temperature range	-20℃~50℃
Humidity range	15%~90% RH non condensation
Pressure range	standard atmospheric pressure±10%
Lifespan	2 years

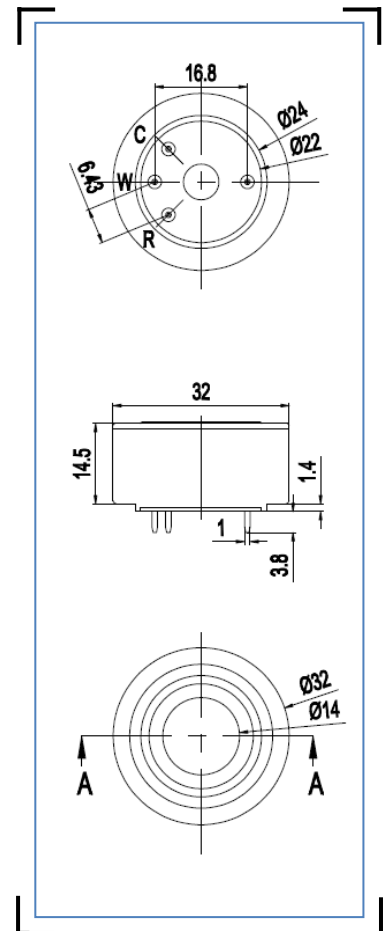

Fig1.Sensor Structure

## Basic Circuit

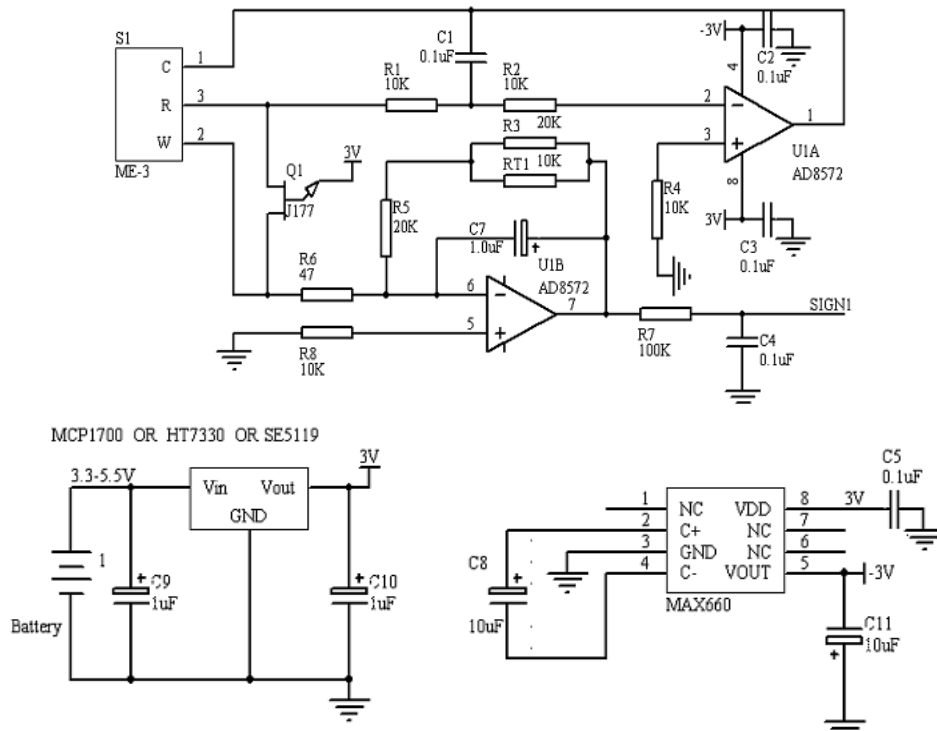

Fig2: MQ-E4<sub>2</sub>H<sub>2</sub> test circuit

### Description of sensor characters

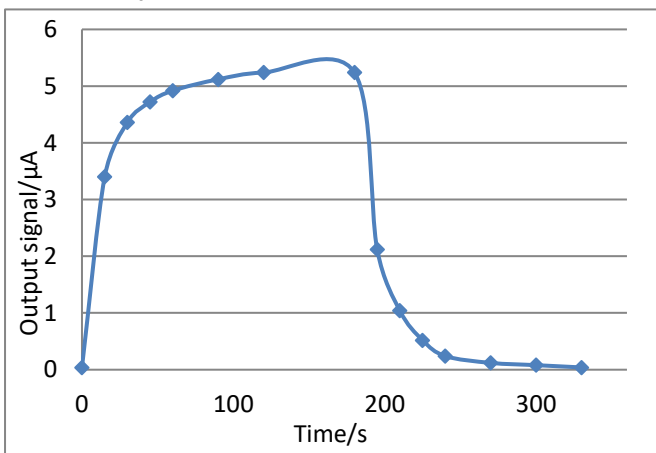

Fig3. Response and Resume

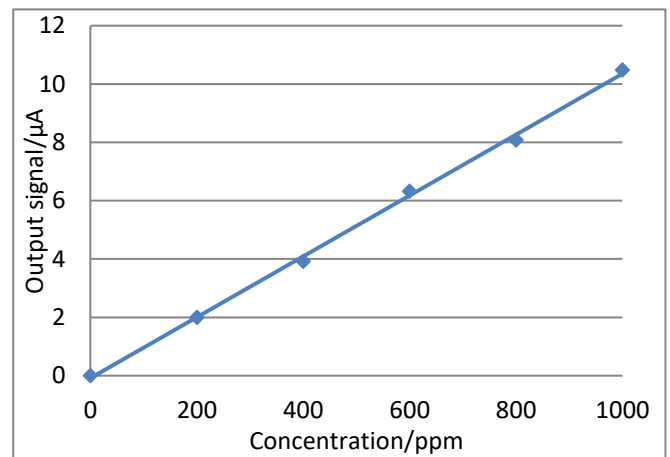

Fig4. Linearity

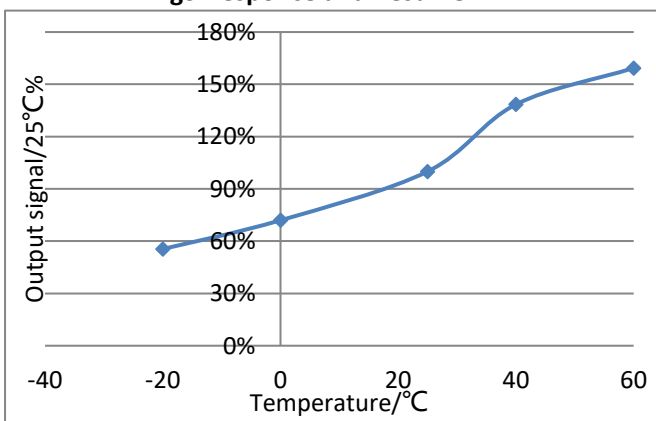

Fig5. Output of sensor at different temperature

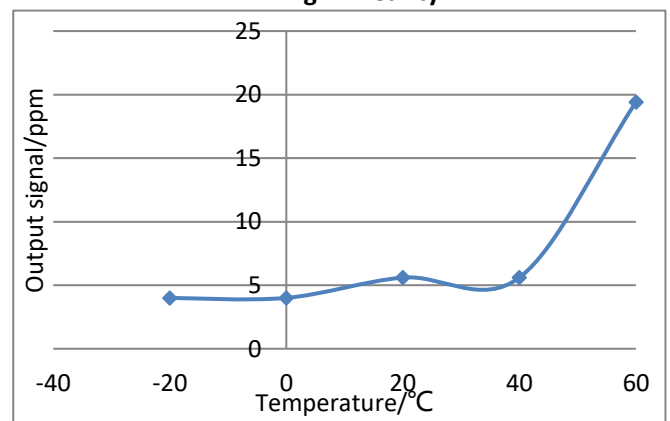

Fig6. Zero output of sensor at different temperature

---

## Cross Interference

MQ-E4-H<sub>2</sub> sensor also can respond to other gases besides target gas H<sub>2</sub>. Following data are the response characteristics of the sensor to interferential gases at certain concentration for your reference.

Interferential Gas	Concentration	MQ-E4-H <sub>2</sub>
H <sub>2</sub> S	15ppm	4ppm
SO <sub>2</sub>	5ppm	0ppm
C <sub>2</sub> H <sub>4</sub>	100ppm	0ppm
NO	35ppm	9ppm
NO <sub>2</sub>	5ppm	2ppm

## Cautions!

- Tin soldering is prohibited.
  - Before using, power on to aging for more than 48 hours is necessary.
  - Pins can't be broke off or bent.
  - Don't disassemble the sensor to avoid the damage caused by electrolyte leakage.
  - Avoid contacting organic solvent (including Silicone rubber and other adhesive), coatings, medicine, oil and high concentration gases.
  - All the electrochemical sensors shall not be encapsulated completely by resin materials, and shall not immerse in oxygen- free environment, otherwise, it will damage the function of sensor
  - All electrochemical sensors shall not be applied in corrosive gas environment, or the sensor will be damaged
  - Zero calibration should be finished in clean air.
  - During test and usage, sensors should avoid the gas inflow vertically
  - The side for inflow can't be choked and polluted.
  - The laminating film above the sensor surface can't be uncovered and damage.
  - Excessive impact or vibration should be avoided
  - Do not use the sensor when the shell is damaged
  - It takes some time for the sensor to return to normal state after it is applied in high concentration gas
-

- 
- Working electrode and reference electrode of the sensor shall be in short circuit when stored
  - Prohibit to use the hot cement or sealant of which the curing temperature is higher than 80°C to make the capsulation for the sensor.
  - Prohibit storage and usage for long time in alkaline gases with high concentration.
-