



# Electrochemical CH<sub>2</sub>O Detection Module

(Model: TE08-CH<sub>2</sub>O)

# User's Manual

Version: 1.7

Valid from: 2020-04-17

Taiyuan Tengxing sensor technology Co., Ltd

# Statement

- 1.The copyright of instructions belong to Taiyuan Tengxing sensor technology Co., Ltd(hereinafter referred to as the Company), nobody is allowed to copy, translate, spread or store without written approval.
- 2.Thanks for using our product. In order to use the products more smoothly, reduce faults result from inappropriate using, please read the instructions carefully before using and follow the rules suggested strictly. Anyone who don't follow the instructions, disassemble or change the internal components without permission will afford the loss.
- 3.The color, style and size of the product is subject to the object you received.
- 4.The company follows the idea of scientific and technological progress, make efforts to product-improving and technology-innovating. So we have the right to improve product without prior notice.
- 5.Please make sure it's valid before using the instructions. Any good suggestions from you is welcomed.
- 6.The instructions should be well kept.

**Taiyuan Tengxing sensor technology Co., Ltd**

# Electrochemical CH<sub>2</sub>O Detection Module ZE08-CH<sub>2</sub>O

**Profile**

TE08-CH<sub>2</sub>O is a general-purpose and miniaturization electrochemical formaldehyde detection module. It utilizes electrochemical principle to detect CH<sub>2</sub>O in air which makes the module with high selectivity and stability .It is built-in temperature sensor to make temperature compensation. It has the digital output and analog voltage output at the same time. It is a combination of mature electrochemical detection principle and sophisticated circuit design.

**Features**

- \*High sensitivity & resolution, Low power consumption, Long life
- \*UART/Analog Voltage/PWM wave output
- \* Good stability, excellent ability of Anti-interference
- \* Temperature compensation , Excellent Linear output

**Main Application**

Portable detector, air-quality monitor, air cleaner, air renewal system, air conditioner, smart home.



**Technical Parameters Table 1.**

Model No.	TE08-CH <sub>2</sub> O
Target Gas	CH <sub>2</sub> O
Interference Gas	Alcohol, CO &ect.
Output Data	DAC(0.4~2V standard voltage output, corresponding concentration: 0 ~ full scale )
	UART output(3V TTL Electrical Level)
Working Voltage	3.7V~5.5V
Warm up time	≤3 minutes
Response time	≤60s
Resume time	≤60s
Detection Range	0~5ppm
Resolution	≤0.01ppm
Operating Temp.	-20℃~50℃
Operating Hum.	15%RH-90%RH(No condensation)
Storage temp.	0~25℃
Working life	5 years (in clean air 18 ℃ ~ 25 ℃)

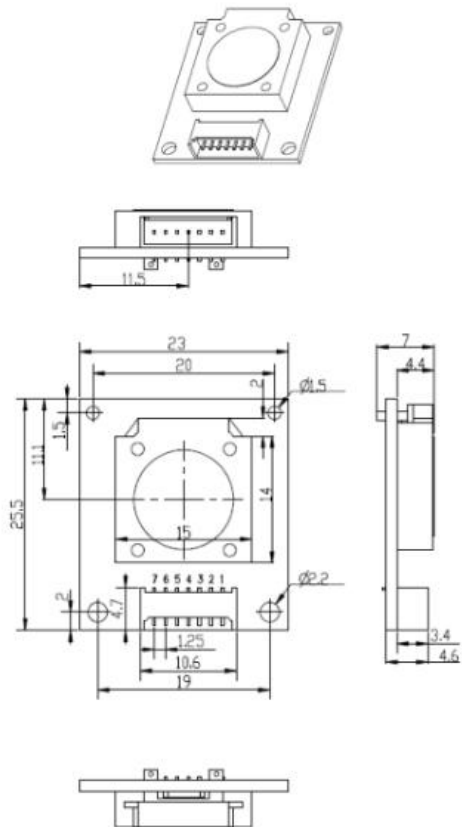
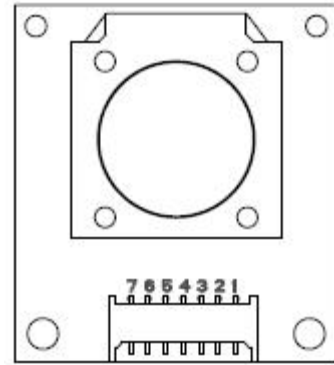

**Fig 1: Module structure**

**Pin Description:**

**Table 2**

PIN	Instruction
Pin1	Reserved
Pin2	DAC (0.4~2V for 0-full scale)
Pin3	GND
Pin4	Vin (Voltage input 3.7V~5.5V)
Pin5	UART (RXD) 0~3.3V data input
Pin6	UART (TXD) 0~3.3V data output
Pin7	Reserved



**Fig2. Pin figure of the Module**

**Communication Protocol:**

**1. General Settings**

**Table 3**

Baud Rate	9600
Data Bits	8
Stop Bits	1
Parity	None

**2. Commands**

There are two communication type: active upload type and Q&A type. The default type for this module is active upload and it sends gas concentration every other one second.

If the user switched to the question and answer mode, need to re-switch to active upload, send the following command line format:

**Table 4**

Byte0	Byte1	Byte2	Byte3	Byte4	Byte5	Byte6	Byte7	Byte8
Start Byte	reserved	<b>Switch command</b>	<b>Active upload</b>	reserved	reserved	reserved	reserved	checksum
0xFF	0x01	<b>0x78</b>	<b>0x40</b>	0x00	0x00	0x00	0x00	0x47

**Active upload data display format is as follows:**

**Table 5**

Byte0	Byte1	Byte2	Byte3	Byte4	Byte5	Byte6	Byte7	Byte8
Start Byte	Gas Name CH2O	Unit ppb	No decimal byte	<b>Concentration (High Byte)</b>	<b>Concentration (Low Byte)</b>	Full Range (High Byte)	Full Range (Low Byte)	Checksum
0xFF	0X17	0x04	0x00	<b>0x00</b>	<b>0x25</b>	0x13	0x88	0x25

Gas concentration value=High byte of concentration \*256+ Low byte of concentration.

When converted to PPM: PPM = PPB / 1000.      1PPM × 1.25 = 1.25mg / m3

When the user needs the question and answer mode, you can send the following command format to close the active upload data, and then send the command to read the concentration can be. Close the active command line format as follows:

**Table 6**

Byte0	Byte1	Byte2	Byte3	Byte4	Byte5	Byte6	Byte7	Byte8
Start Byte	reserved	Switch command	Q&A	reserved	reserved	reserved	reserved	checksum
0xFF	0x01	0x78	0x41	0x00	0x00	0x00	0x00	0x46

In question and answer mode, the command format for reading the concentration is as follows:

**Table 7**

Byte0	Byte1	Byte2	Byte3	Byte4	Byte5	Byte6	Byte7	Byte8
Start Byte	reserved	command	reserved	reserved	reserved	reserved	reserved	checksum
0xFF	0x01	0x86	0x00	0x00	0x00	0x00	0x00	0x79

The returned sensor density value display format is as follows:

**Table 8**

Byte0	Byte1	Byte2	Byte3	Byte4	Byte5	Byte6	Byte7	Byte8
Start Byte	command	High byte(ug/m3)	Low byte (ug/m3)	reserved	reserved	High byte (ppb)	High byte (ppb)	checksum
0xFF	0x86	0x00	0x28	0x00	0x00	0x00	0x20	0x32

Gas concentration value=High byte of concentration \*256+ Low byte of concentration

### 3 .Checksum and calculation

```

/*****
* Function Name: unsigned char FucCheckSum(uchar *i,uchar ln)
* Functional description: Sum check 【Take Not(Byte1+Byte2+...Byte7) +1】
* Function declaration: Take Not(Byte1+Byte2+...ByteX (X>2))

*****/
unsigned char FucCheckSum(unsigned char *i,unsigned char ln)
{
    unsigned char j,tempq=0;
    i+=1;
    for(j=0;j<(ln-2);j++)
    {
        tempq+=*i;
        i++;
    }
    tempq=(~tempq)+1;
    return(tempq);
}

```

Cross interference gas

Table 9

Gas	Concentration/ppm	Equivalent CH <sub>2</sub> O/ppm
CH <sub>2</sub> O	5	5
C <sub>6</sub> H <sub>6</sub>	10	0.1
C <sub>7</sub> H <sub>8</sub>	10	0.46
C <sub>2</sub> H <sub>4</sub> O <sub>2</sub>	200	0.52
C <sub>2</sub> H <sub>5</sub> OH	100	40.6
H <sub>2</sub> S	50	3
CO	200	0.64

Packing:

1. Place the sensor in the same direction in the blister tray.
2. Place the sensor's blister trays in the appropriate number of layers according to the box specifications.
3. Place the packaged sensor in the carton.
4. The carton is sealed and packed.
5. Orders with a single shipment less than the minimum package are not subject to this specification.

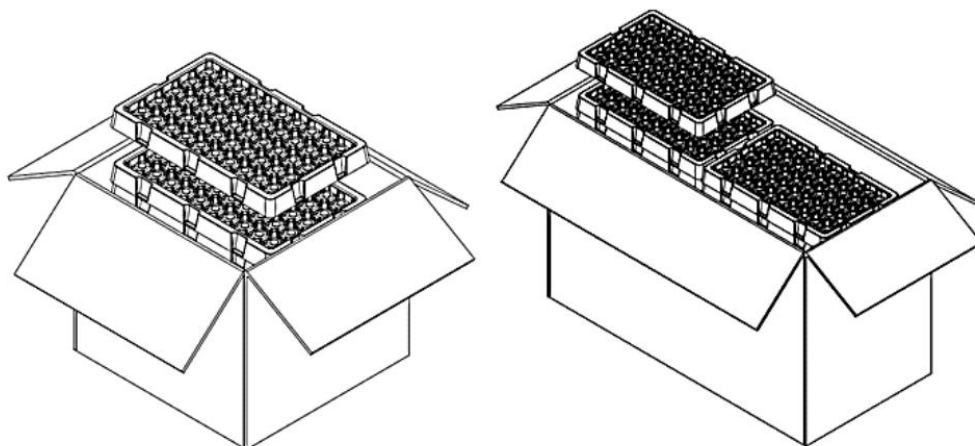
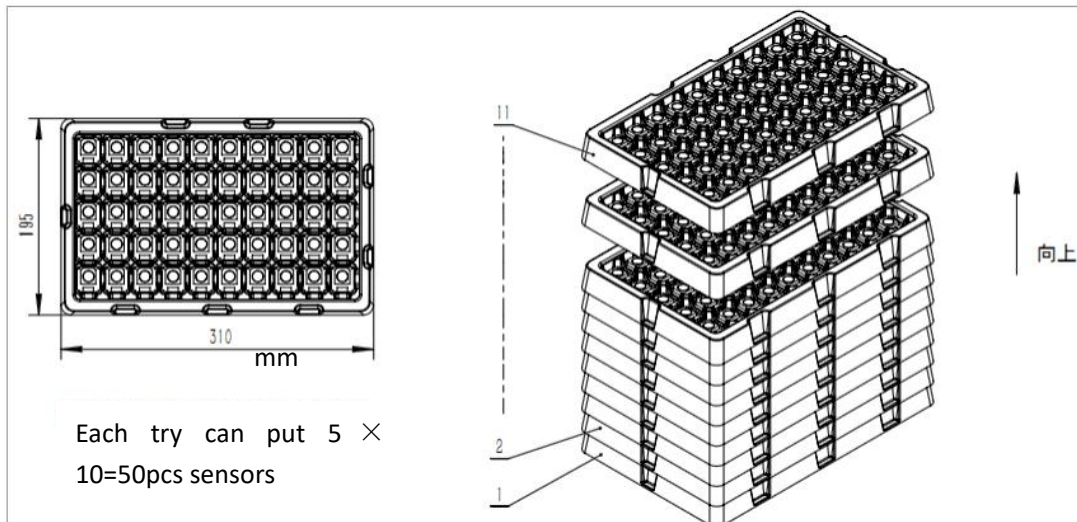

---

### **Cautions:**

1. Sensor shall Avoid organic solvent, coatings, medicine, oil and high concentration gases
2. The module may not be completely encapsulated with resin material, nor may it be immersed in an oxygen-free environment, otherwise the performance of the sensor may be damaged;
3. Modules cannot be used in environments with corrosive gases for long periods of time, and corrosive gases can damage the sensor;
4. Excessive impact or vibration should be avoided;
5. The initial power-up of the module needs to be preheated for 24-48 hours, so that the module is fully stabilized and then tested normally.
6. Please do not use the modules in systems which related to human being’s safety.
7. Please do not use the modules in strong air convection environment.
8. Do not leave the module in a high concentration of organic gas for a long time. If it is placed for a long time, it will cause the sensor zero to drift and recover slowly.
9. It is forbidden to use hot melt adhesive or sealant package module with curing temperature higher than  $80^{\circ}\text{C}$ ;
10. It is forbidden to store and use in high concentration alkaline gas for a long time.

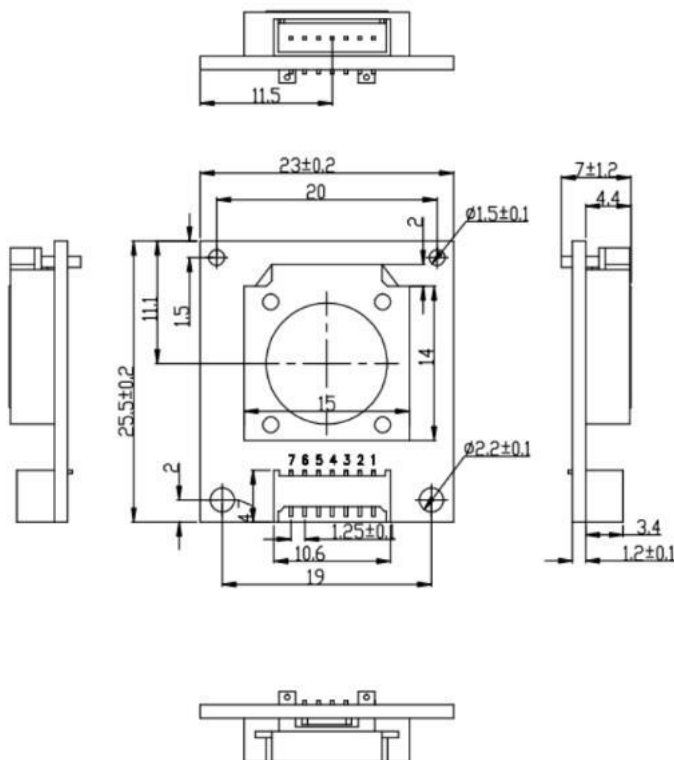

**Unit:** mm

**Tolerance:**  $\pm 0.2$ mm

---