



NDIR Infrared CH4 Gas Sensor

(Model: TX721-J1)

Manual

Version: 2.9

2022.12.01

Taiyuan Tengxing sensor technology Co., Ltd

Statement

1.The copyright of instructions belong to Taiyuan Tengxing sensor technology Co., Ltd(hereinafter referred to as the Company), nobody is allowed to copy, translate, spread or store without written approval.

2.Thanks for using our product. In order to use the products more smoothly, reduce faults result from inappropriate using, please read the instructions carefully before using and follow the rules suggested strictly. Anyone who don ' t follow the instructions, disassemble or change the internal components without permission will afford the loss.

3.The color, style and size of the product is subject to the object you received.

4.The company follows the idea of scientific and technological progress, make efforts to product-improving and technology-innovating. So we have the right to improve product without prior notice.

5.Please make sure it ' s valid before using the instructions. Any good suggestions from you is welcomed.

6.The instructions should be well kept.

Taiyuan Tengxing sensor technology Co., Ltd

TX721-J1 NDIR Infrared CH4 Sensor

1. Introduction

TX721-J1 infrared gas sensor is a miniature universal intelligent sensor, which adopts NDIR theory to detect concentration of CH4 in air and has good selectivity, stable performance, long life, also is independent of

Oxygen. The inside temperature sensor could be used for temperature compensation. This miniature infrared gas sensor is developed by the tight integration of mature infrared absorbing gas detection technology, micro machine workout and superior circuit design.

It is convenient in use and instead of catalytic component directly, widely used in various occasions with flammable and explosion hazard gas.

2.Features

- High sensitivity, high resolution, fast response
- Output method: UART, analog voltage signal
- Temperature compensation, excellent linear output
- Excellent stability, long lifespan
- Anti-poisons, anti-vapor interference
- Can replace catalytic type gas sensor directly.

3.Applications

Widely used for HVAC refrigeration, air monitoring indoor, industrial-process control and safety protection, agriculture, and animal husbandry.

4.Main Parameters

Fig1.Technical Parameters

Detection Gas	Methane (CH4)
Working Voltage	3.6~5V DC (Need to be powered by safety barrier)
Average Current	<85mA
Interface Level	3.0V
Detection range	0~10%vol (selectable, refer fig2.)
Output Signal	UART (3.0V)
	0.4~2.0V DC
Warm-up time	3 min
Response time	T90<30 seconds
Working Temperature	-20°C ~ 60°C
Working Humidity	0~95%RH (no condensation)
Sizes	Φ 20 × 22.4mm
Weight	35g
Lifetime	>5 years
Defense Grade	IP54
Power, communication terminal Intrinsic safety	Ui=7.5VDC, Ii=265mA, Pi=0.5W, Ci=10 μF, Li=0mH

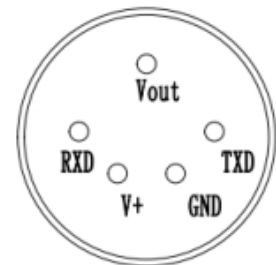
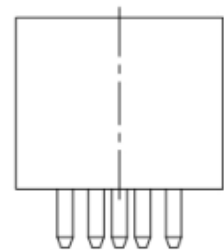
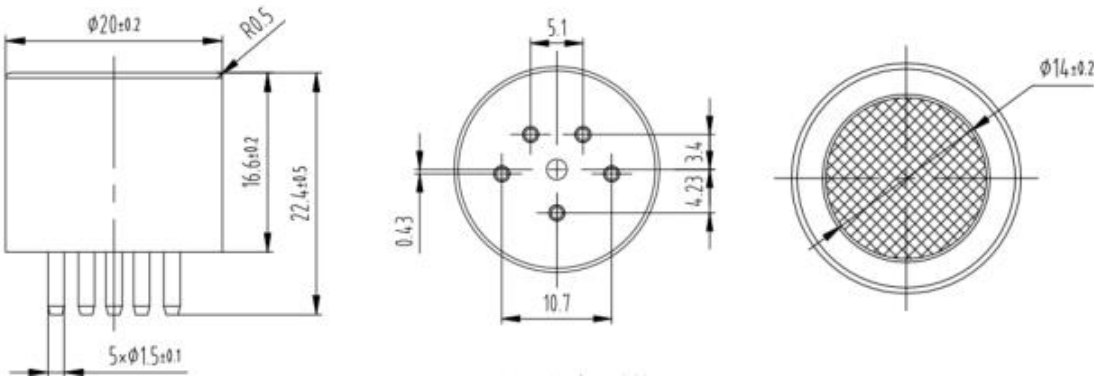

Fig2.Measuring Range and Resolution

Target Gas	Molecular Formula	Measuring Range	Resolution	No. of decimal	Note
Methane	CH4	0~5.00%VOL	0.01%VOL	2	Temperature compensation
		0~10.00%VOL		2	
		0~100%LEL	1%LEL	none	

5.Struction Size



Pin definition

Name of Pin	Explanation
Pin 2	Vin Voltage input
Pin 1	GND
Pin 4	Vout (0.4~2 V)
Pin 3	UART (RXD) 0~3.0 V data input
Pin 5	UART (TXD) 0~3.0 V data output

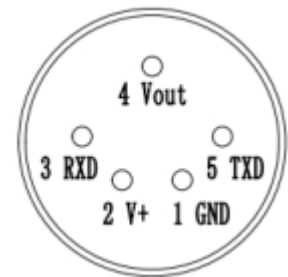

6.Output way.

6.1 Analog Output

The output of Vout is proportional to the gas concentration, 0.4-2.0V output stands for 0 to full range.

Connection: Vin -5V, GND- Power Ground, Vout-ADC input.

After warm-up, Vout will show the voltage standing for the gas concentration.

If self-checking detects a fault, the output voltage is 0V.

Output concentration = sensor range * output voltage (V) / (2 - 0.4).

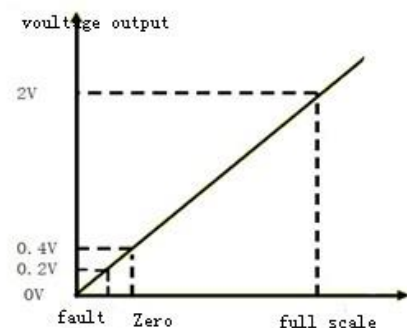

6.2 Digital Output

Please refer MH-440D communication protocol.

Intrinsically safe explosion-proof

- This product meets the standards of GB3836.1-2010 "Explosive Atmosphere Part 1: General Requirements for Equipment" and GB3836.4-2010 "Explosive Atmosphere Part 4: Equipment Protected by Intrinsically Safe "i" standards"; the explosion-proof mark is Exib II B T4 Gb, it is suitable for zone 1 and zone 2, contains Class IIA, T1-T3 explosive environment formed by the flammable gas, mixture of steam and air; it has passed the inspection by the National Quality Inspection Center for Explosion-proof Electrical Products and obtained the explosion-proof certificate. When using, please note the following:
 - The intrinsically safe power supply must be used to power the sensor, otherwise the explosion-proof performance will be affected.
 - It is forbidden to replace the sensor in dangerous places.
 - It is forbidden to disassemble or replace the sensor element to avoid affecting the explosion-proof performance.
 - It is not allowed to replace components or structures, so as not to affect the explosion-proof performance.
 - The installation and wiring of the safety barrier must be carried out in accordance with the safety barrier instruction manual, and the safety barrier must obtain an explosion-proof certificate.

Connection diagram of intrinsically safe explosion-proof system

The on-site installation must comply with the relevant regulations of the GB3836.15—2000 "Electrical Equipment for Explosive Gas Environment Part 15: Electrical Installation in Hazardous Locations (Except Coal and Mines).

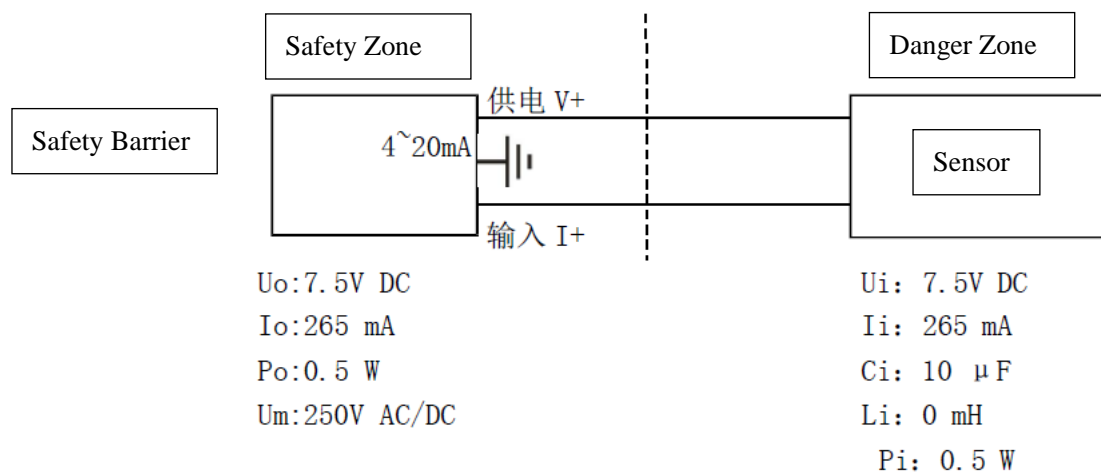

The distribution parameters of the connecting cable between the safety barrier and the sensor should meet:

$$C_c \leq C_o - C_i \quad L_c \leq L_o - L_i \quad U_i \geq U_o \quad I_i \geq I_o \quad P_i \geq P_o$$

Note:

U_o : Maximum output voltage of safety barrier.

I_o : Maximum output current of safety barrier

P_o : Maximum output power of safety barrier

C_o : Maximum external capacitance of safety barrier

L_o : the maximum external inductance of the safety barrier (see the safety barrier instructions for the above parameters book)

C_c : Maximum allowable distributed capacitance of connecting cable

U_i : sensor maximum input voltage

I_i : Maximum sensor input current

P_i : sensor maximum input power

C_i : Maximum internal capacitance of the sensor

Li: Maximum internal inductance of the sensor

Lc: Maximum allowable distributed inductance of connecting cable.

7. Cautions for Maintenance

7.1 The sensor should be calibrated regularly. The suggested cycle time is 6 months.

7.2 Do not use the sensor in the high dusty environment for long time.

7.3 Please use the sensor with correct power supply.

7.4 Forbid to weld the sensor pins directly.

7.5 Forbid to cut the sensor pins. Output concentration = sensor range * output voltage (V) / (2 - 0.4).

Output concentration = sensor range * output voltage (V) / (2 - 0.4).