



Vehicle Hydrogen Leakage sensor
(**Model ZC01-H2**)

User's Manual

Version: 1.3

Valid from: 2024-01-15

Taiyuan Tengxing sensor technology Co., Ltd

Statement

1.The copyright of instructions belong to Taiyuan Tengxing sensor technology Co., Ltd(hereinafter referred to as the Company), nobody is allowed to copy, translate, spread or store without written approval.

2.Thanks for using our product. In order to use the products more smoothly, reduce faults result from inappropriate using, please read the instructions carefully before using and follow the rules suggested strictly. Anyone who don ' t follow the instructions, disassemble or change the internal components without permission will afford the loss.

3.The color, style and size of the product is subject to the object you received.

4.The company follows the idea of scientific and technological progress, make efforts to product-improving and technology-innovating. So we have the right to improve product without prior notice.

5.Please make sure it ' s valid before using the instructions. Any good suggestions from you is welcomed.

6.The instructions should be well kept.

Taiyuan Tengxing sensor technology Co., Ltd

ZC01-H2 vehicle hydrogen leakage sensor

Product description

ZC01-H2 hydrogen leakage sensor is mainly used in the monitoring of hydrogen leakage in the hydrogen fuel cell engine and hydrogen

supply pipeline system. The catalytic combustion sensor of the MEMS process is used to detect the hydrogen concentration. This sensor is a high-performance module made by closely combining mature detection technology with high-quality design circuits.



Features

- ◆ MEMS process
- ◆ Intelligent algorithms
- ◆ Anti-electromagnetic interference
- ◆ CAN interface output
- ◆ Excellent repeatability and stability
- ◆ Long service life

Mainly application

Hydrogen energy vehicles, hydrogen energy preparation, hydrogen energy storage, and hydrogen energy transportation.

Technical Parameters:

Model	ZC01-H2
Detection theory	Catalytic combustion
Detecting gas	Hydrogen (H ₂)
Supply voltage(V)	12V/24V DC (9-36V DC)
Measuring range	0-40000ppm
Detection accuracy	±1000PPM is less than 1% H ₂ & ±10% is higher than 1% H ₂
Start-up time	<1s
Response Time	≤3s (T90)
Recovery Time	≤10s
Rated Current	<15mA
Power Consumption	≤0.2W@DC 12V / ≤0.2W@DC 24V
Working Temperature	-40~ +125 °C
Working Humidity	≤95%RH (No condensation)
Storage Temperature	-40~ +125 °C
Output signal	CAN
Protection Grade	IP68
Catalytic conditions	Oxygen content not less than 15%

Product Pin Definition

Adapter model: 6189-1231 (Sumitomo, Japan)

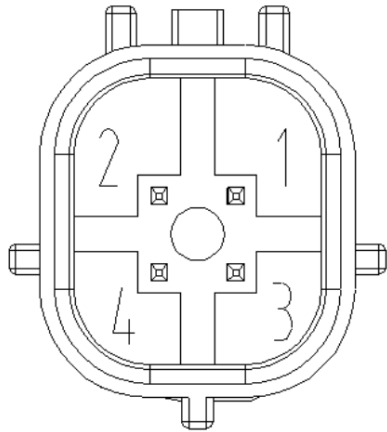

Plug-in definition

Item	Pin Name	Description
1	CAN H	CAN communication H-pin
2	CAN L	CAN communication L-pin
3	VIN	Input voltage positive
4	GND	Input voltage negative

Figure 1. Connection definition diagram

Hydrogen leak sensor CAN output technical protocol

Item	Description
Protocol	The CAN communication protocol is as follows (can be changed according to customer requirements)
Baud rate	250kbps
Output time interval	500ms
Amount of data	8 byte (See table below for detailed definitions)
CAN communication ID address	CAN default communication address 0x19FF0891 (can be changed according to customer requirements)

CAN Protocol Instruction Code Technical Definition Details

Byte	Data	Data range	Description
0	Hydrogen gas concentration	0 to 220	H ₂ Concentration (PPM)=(output value -10)*500
1		255	Invalid concentration data (when sensor status code is 2)
2	Address number	0 to 15	From 0 to 15, used to identify the channel number
3	Sensor status code	0, 1 or 2	0: Normal detection status 1: Within 3 seconds after power-on 2: The sensor is abnormal
4	Fixed value	0	
5	Fixed value	0	
6	Fixed value	0	
7	Cycle count code	0 to 255	Count from 0 to 255

Sensor characteristic description

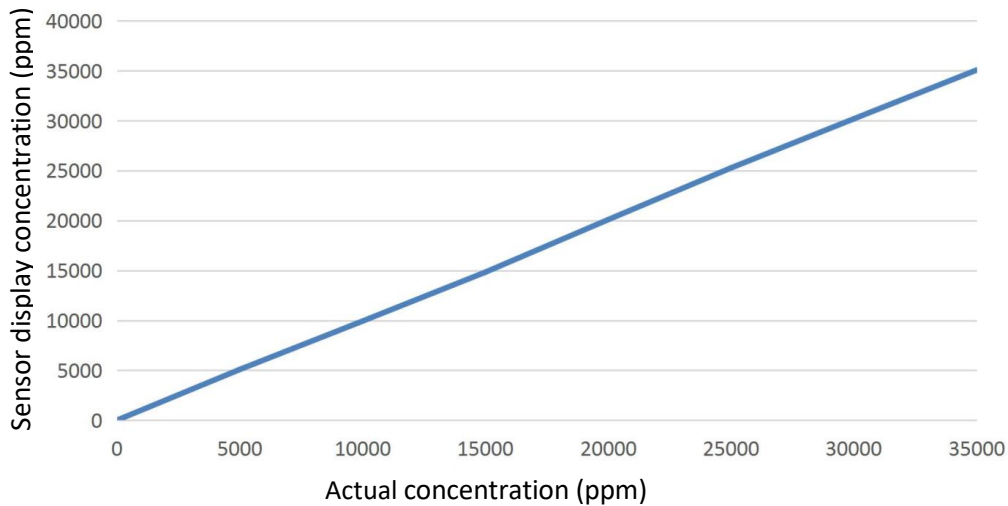

Figure 2. Sensor Linear Curve

Use and care

Conditions that must be prohibited

- ◆ Avoid prolonged exposure to volatile silicide vapor, although the sensor has passed the anti-silane poisoning test under the US SAE-J3089 standard, it should still be avoided for a long time in the presence of silicone binders, silicone rubber, hairspray, putty or other places containing silicone plastic additives.
- ◆ Avoid highly corrosive environment, the sensor is exposed to high concentrations of corrosive gases (such as sulfide, chlorine, fluorine, acid gas, etc.), which will not only cause corrosion and damage to the sensor shell and internal structure, but also cause irreversible changes in the properties of sensitive materials.
- ◆ Alkali, alkali metal salts, halogen contamination sensors contaminated by alkali metal salt spray, or exposed to high concentrations of halogens (such as iodine vapor, freon, etc.), can also cause performance deterioration.
- ◆ If the voltage applied to the sensor is higher than the specified value, it will cause damage to the internal core structure of the sensor, resulting in irreversible damage.

Conditions to avoid as much as possible

- ◆ Avoid working in high concentration gas for a long time as much as possible, such as direct spray of Hydrogen gas to the sensor for a long time, and the combustible gas will have a strong catalytic combustion reaction in the core area of the sensor, which will affect the stability of the sensor.
 - ◆ Long term storage of sensors. Stored for a long time without power, should be in a sealed bag with clean air and free of silicone.
 - ◆ Avoid long-term exposure to extreme environments as much as possible, regardless of whether the sensor is powered on or not, and the sensor performance will be affected by prolonged exposure to extreme conditions such as high temperature, high humidity or high pollution.
 - ◆ Avoid vibration or shock as much as possible, the sensor can pass the vibration and shock test of the automotive level, but frequent and excessive vibration will cause the core structure of the sensor to rupture and cause sensor damage. If the sensor is subjected to a strong impact, or if it is dropped beyond the specified range, it can also cause damage to the sensor.
-

Sensor maintenance

The sensor senses gas concentration based on gas diffusion and passes through a waterproof breathable film. Please regularly check whether the waterproof breathable film is blocked to prevent gas from entering the sensing head cavity.

It is recommended to inspect the sensor air inlet every 3 months to ensure its smoothness. If any damage or blockage is found to the waterproof breathable film, please replace it immediately.

Product External Dimensional Drawing

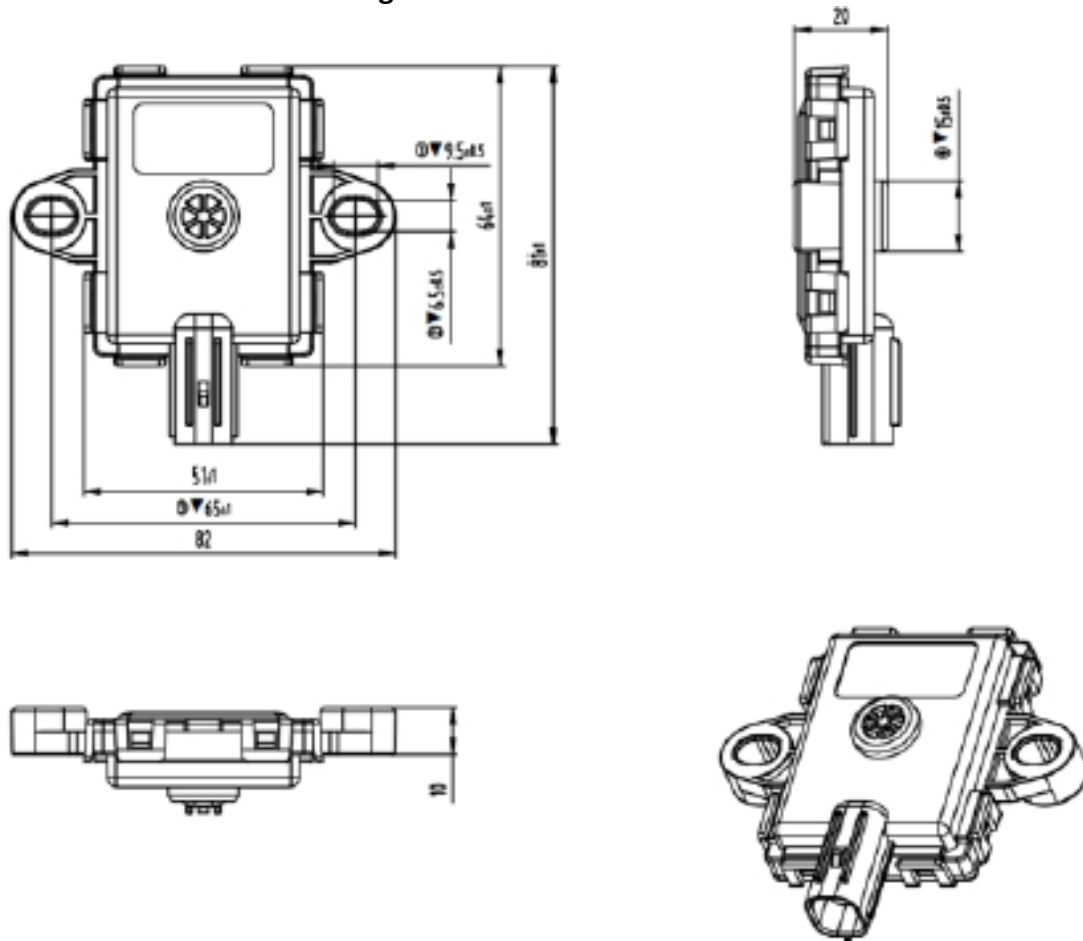

Figure 3. External Dimensional Drawing

Undeclared dimensional tolerance requirements: 6mm~30mm: $\pm 0.5\text{mm}$, 30mm~120mm: $\pm 0.8\text{mm}$

Remarks: Refer to GB/T 1804-C Class-level Size Extreme deviation Requirements

